

C.22R.1643 AZALEA

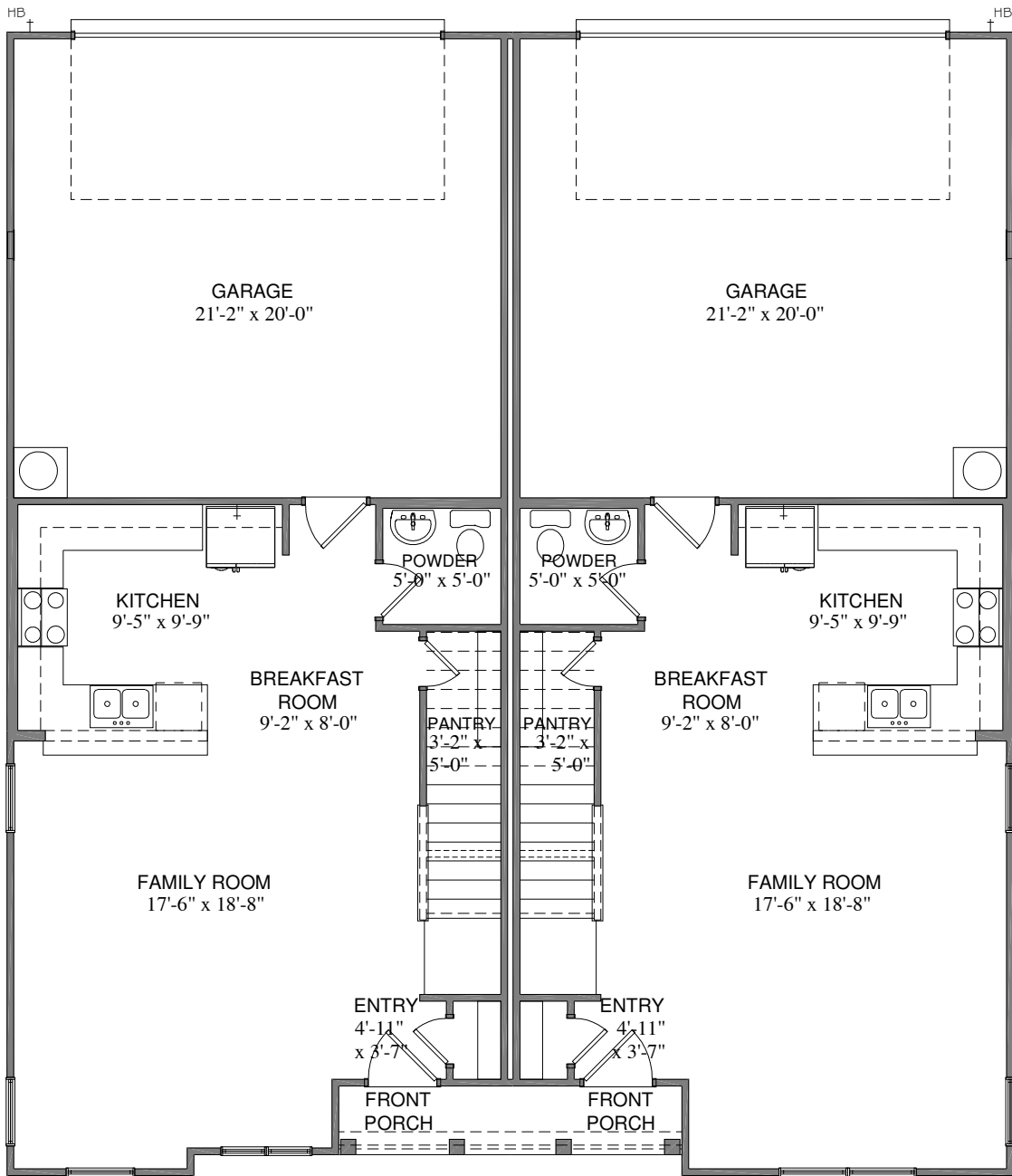
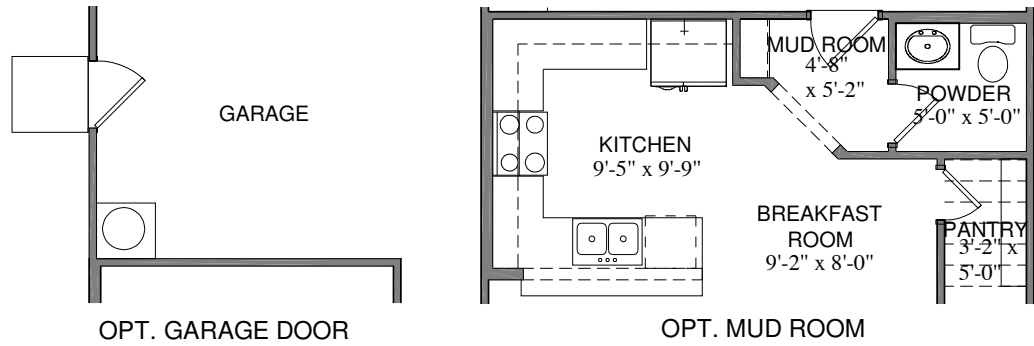

FIRST FLOOR PLAN ELEVATION "A"

SQUARE FOOTAGE TOTALS

UNIT #1

613	1ST FLOOR
1030	2ND FLOOR
23	COVERED PORCHES
446	GARAGE
2112	TOTAL A.U.R.

UNIT #2

613	1ST FLOOR
1030	2ND FLOOR
23	COVERED PORCHES
446	GARAGE
2112	TOTAL A.U.R.

All plans and elevations are subject to change without prior notice. All Village Homes floor plans & elevations are copyrighted. Village Homes will enforce copyright laws to their fullest extent. All plan numbers are approximations of square footage and may vary with alternate elevations.

Please note: In an effort to continually improve our floor plans and elevations, Village Homes reserves the right to make alterations to the designs without prior notice.

C.22R.1643
AZALEA

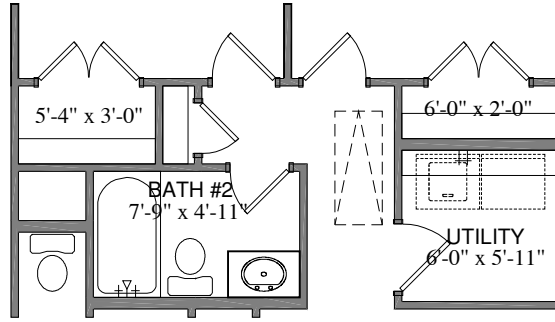

OPT. UTILITY

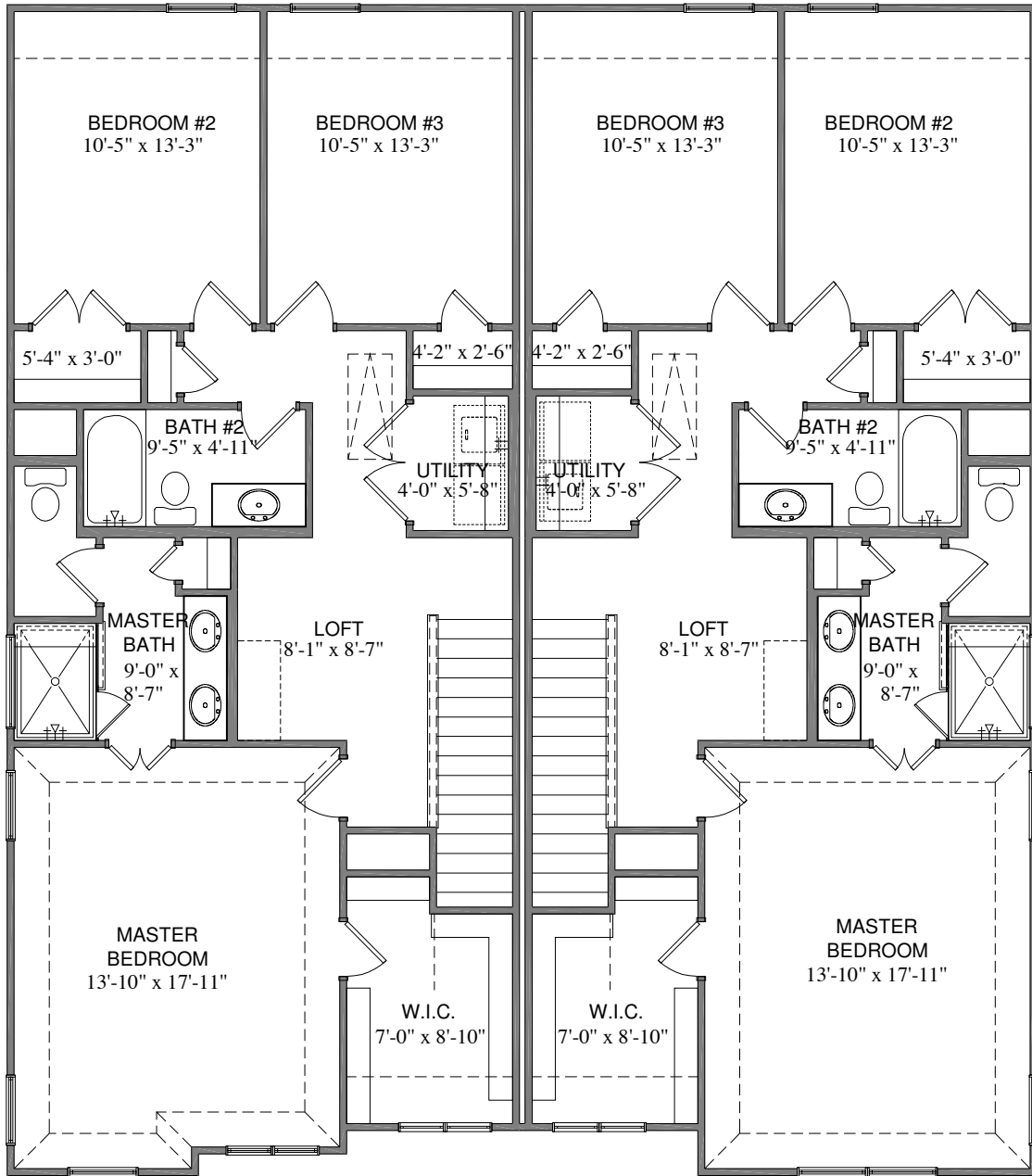

SECOND FLOOR PLAN ELEVATION "A"

All plans and elevations are subject to change without prior notice. All Village Homes floor plans & elevations are copyrighted. Village Homes will enforce copyright laws to their fullest extent. All plan numbers are approximations of square footage and may vary with alternate elevations.

Please note: In an effort to continually improve our floor plans and elevations, Village Homes reserves the right to make alterations to the designs without prior notice.

C.22R.1643 AZALEA

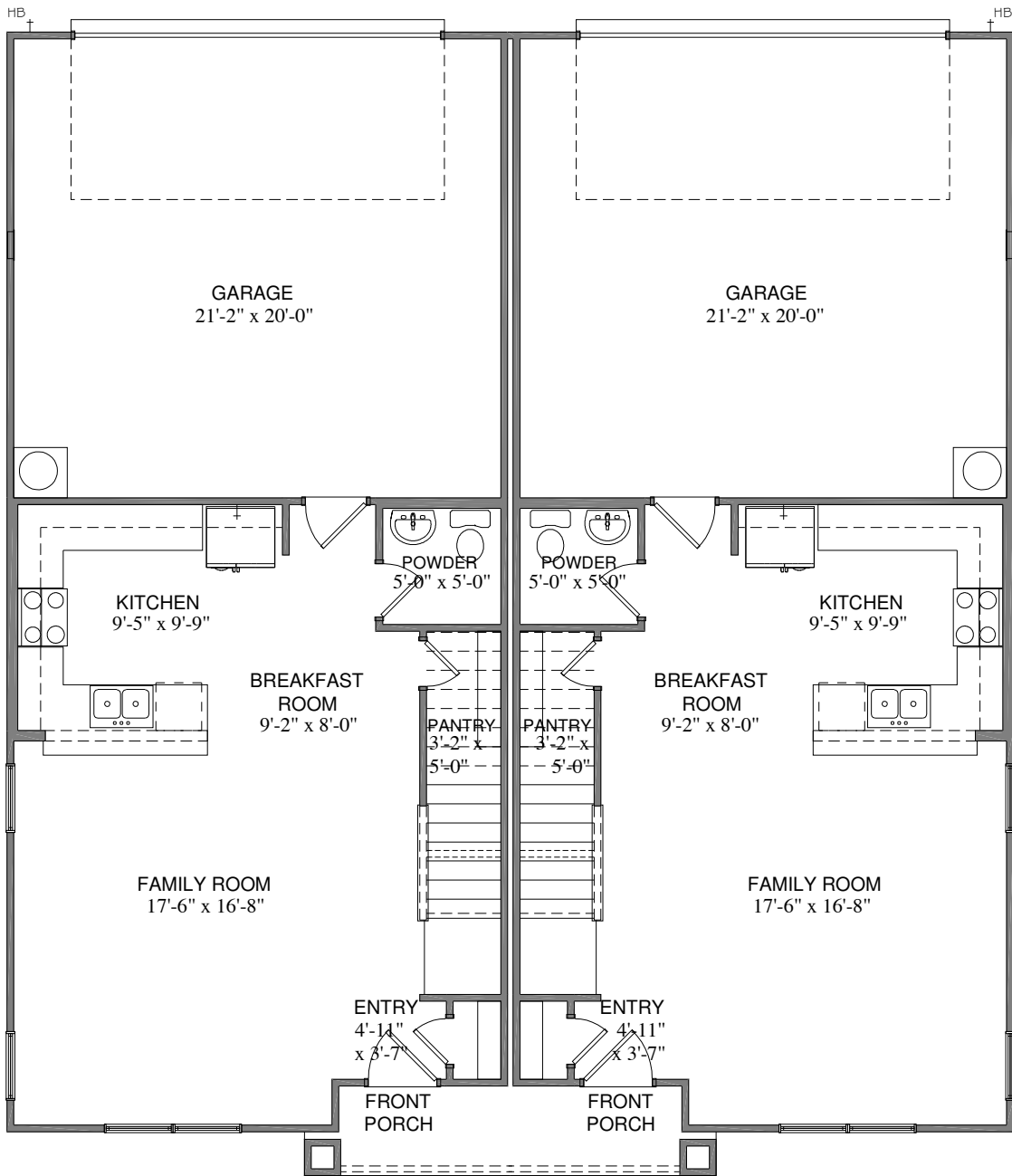
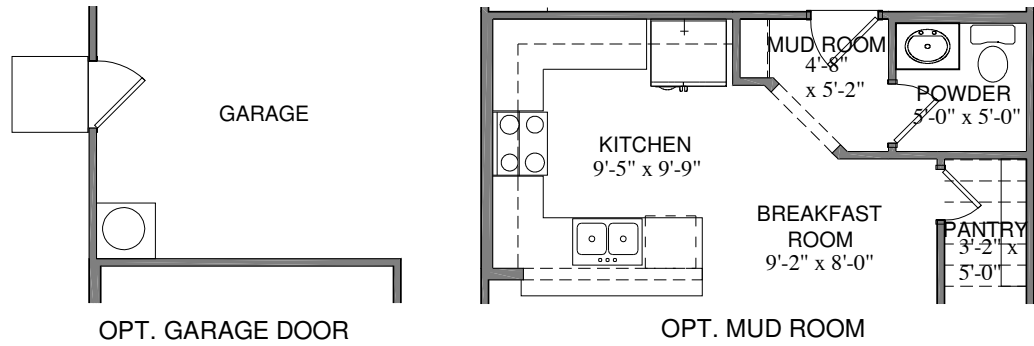

FIRST FLOOR PLAN ELEVATION "B"

SQUARE FOOTAGE TOTALS

UNIT #1

591	1ST FLOOR
1002	2ND FLOOR
23	COVERED PORCHES
446	GARAGE
2017	TOTAL A.U.R.

UNIT #2

591	1ST FLOOR
1002	2ND FLOOR
23	COVERED PORCHES
446	GARAGE
2017	TOTAL A.U.R.

All plans and elevations are subject to change without prior notice. All Village Homes floor plans & elevations are copyrighted. Village Homes will enforce copyright laws to their fullest extent. All plan numbers are approximations of square footage and may vary with alternate elevations.

Please note: In an effort to continually improve our floor plans and elevations, Village Homes reserves the right to make alterations to the designs without prior notice.

C.22R.1643
AZALEA

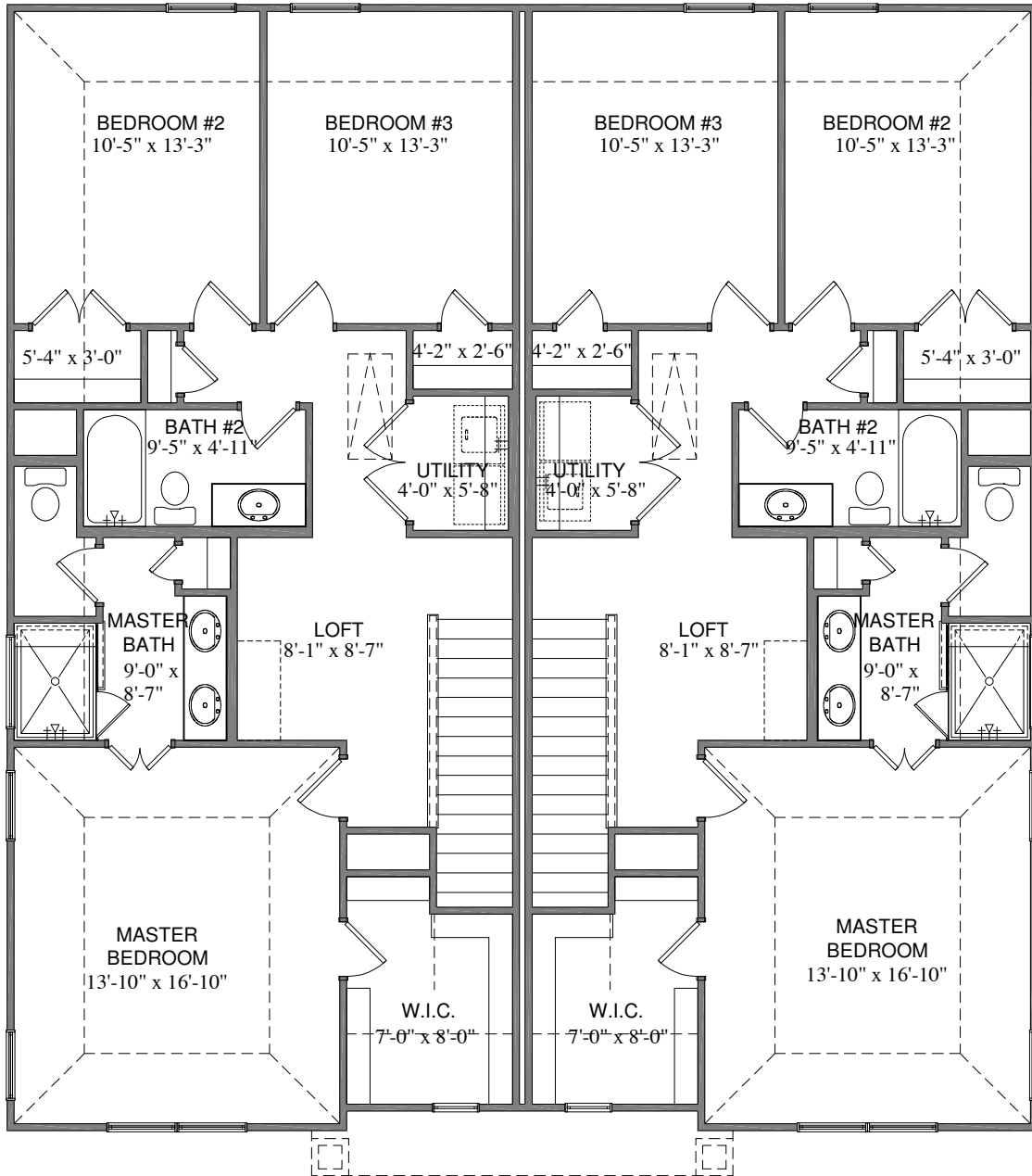
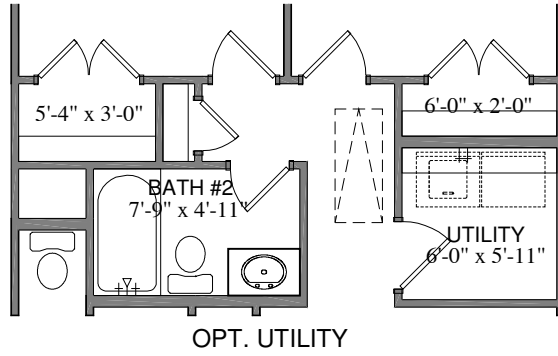

SECOND FLOOR PLAN ELEVATION "B"

All plans and elevations are subject to change without prior notice. All Village Homes floor plans & elevations are copyrighted. Village Homes will enforce copyright laws to their fullest extent. All plan numbers are approximations of square footage and may vary with alternate elevations.

Please note: In an effort to continually improve our floor plans and elevations, Village Homes reserves the right to make alterations to the designs without prior notice.

C.22R.1643 AZALEA

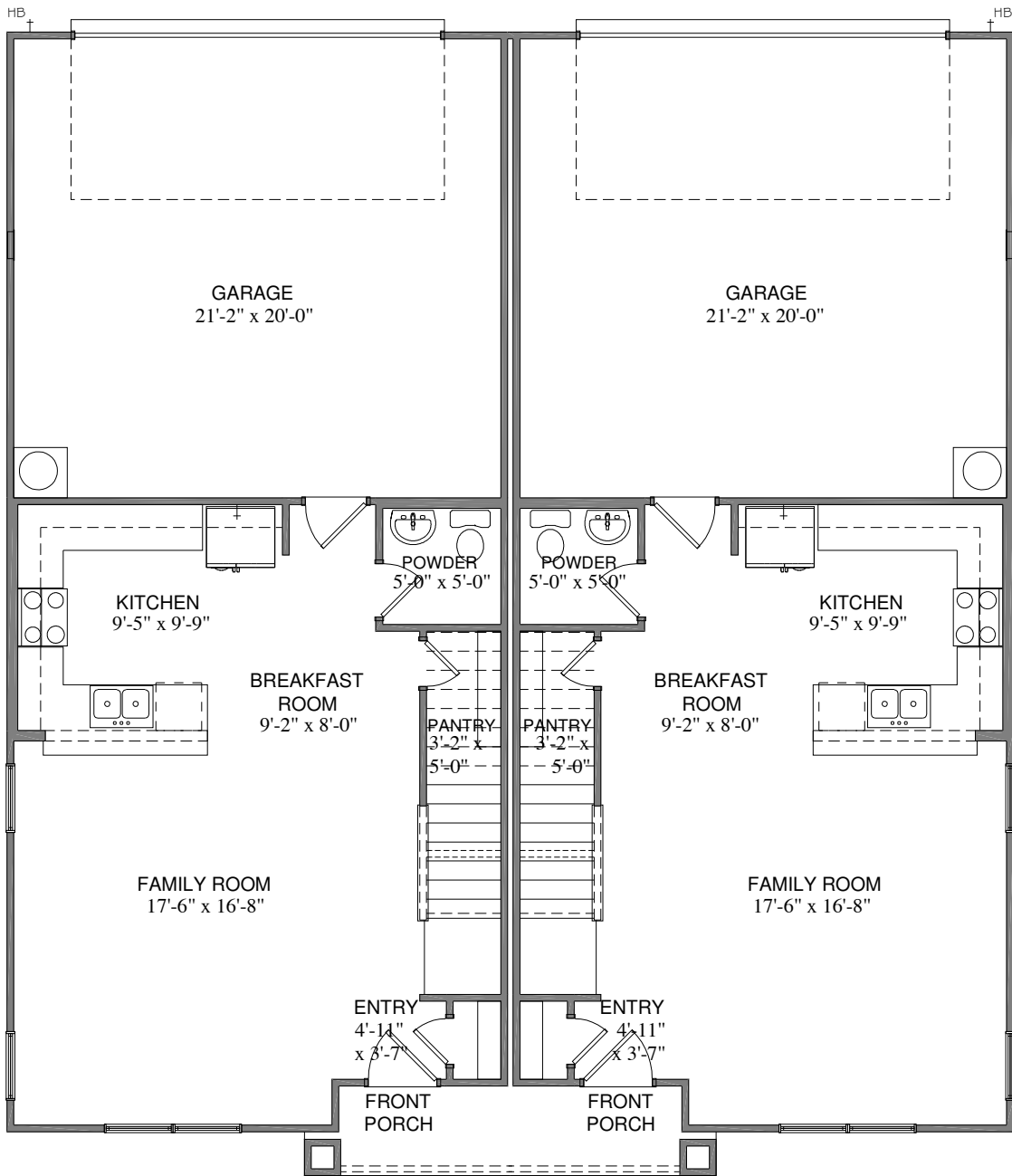
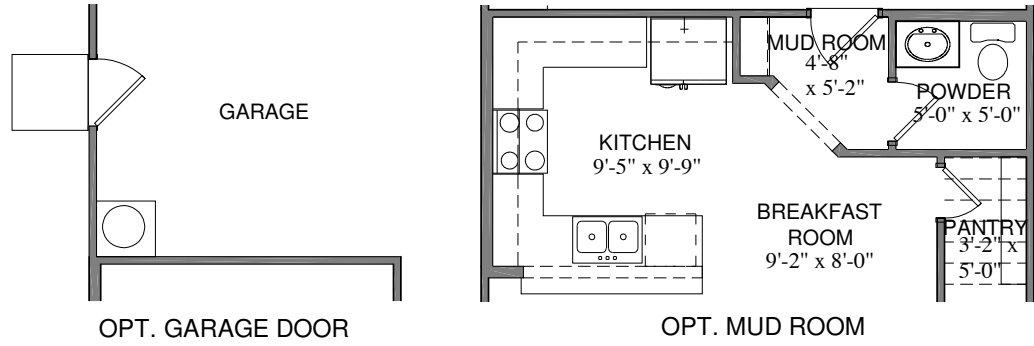

FIRST FLOOR PLAN ELEVATION "C"

SQUARE FOOTAGE TOTALS

UNIT #1

619	1ST FLOOR
1050	2ND FLOOR
29	COVERED PORCHES
446	GARAGE
2144	TOTAL A.U.R.

UNIT #2

606	1ST FLOOR
1030	2ND FLOOR
23	COVERED PORCHES
446	GARAGE
2105	TOTAL A.U.R.

All plans and elevations are subject to change without prior notice. All Village Homes floor plans & elevations are copyrighted. Village Homes will enforce copyright laws to their fullest extent. All plan numbers are approximations of square footage and may vary with alternate elevations.

Please note: In an effort to continually improve our floor plans and elevations, Village Homes reserves the right to make alterations to the designs without prior notice.

C.22R.1643
AZALEA

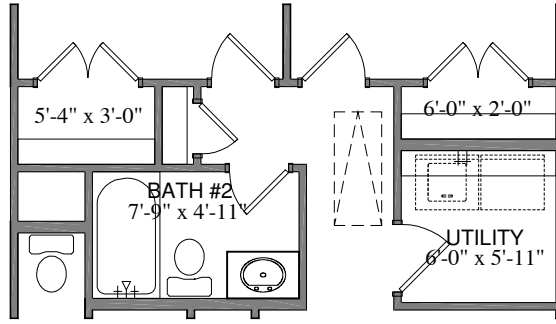

OPT. UTILITY

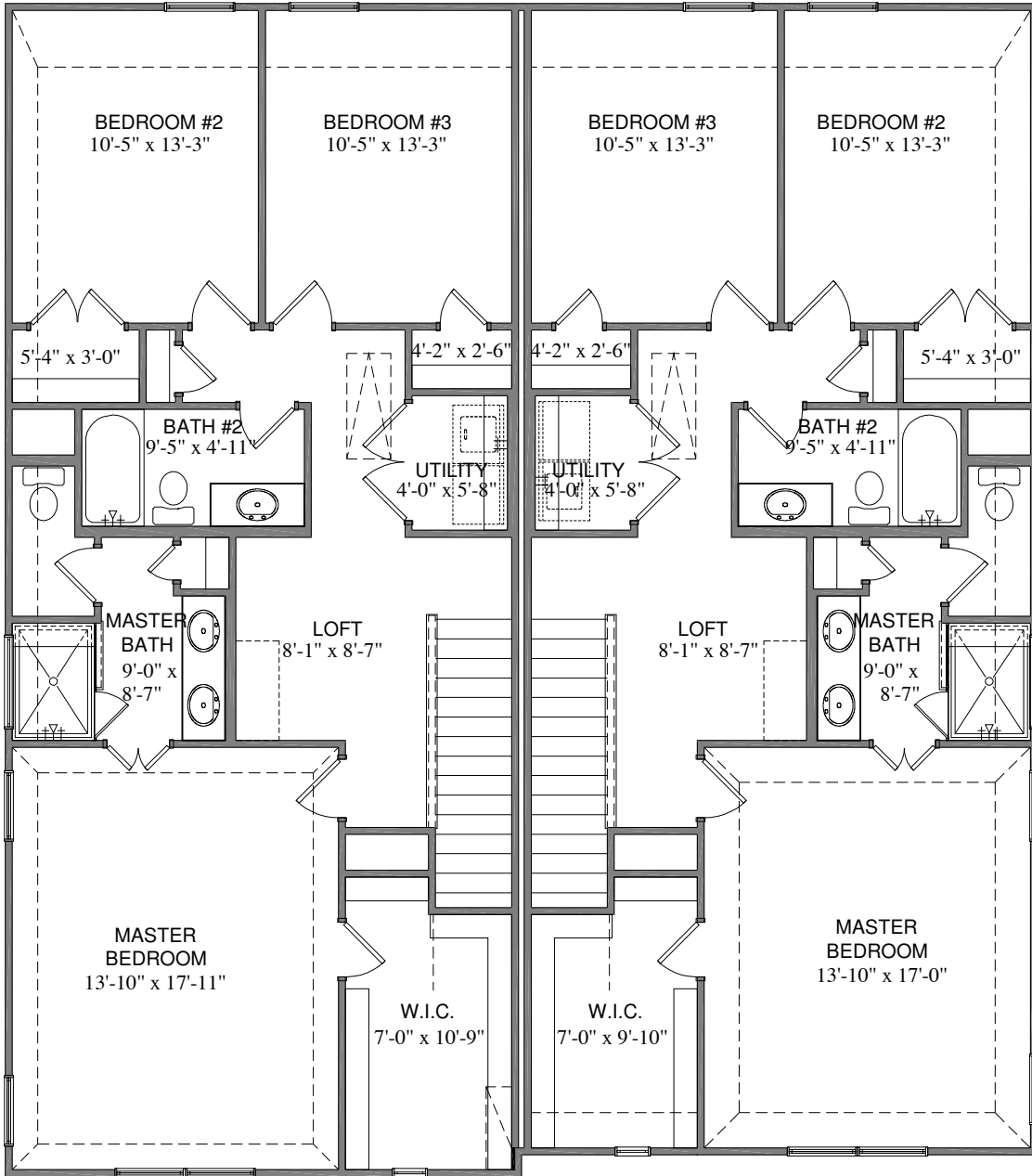

SECOND FLOOR PLAN ELEVATION "C"

All plans and elevations are subject to change without prior notice. All Village Homes floor plans & elevations are copyrighted. Village Homes will enforce copyright laws to their fullest extent. All plan numbers are approximations of square footage and may vary with alternate elevations.

Please note: In an effort to continually improve our floor plans and elevations, Village Homes reserves the right to make alterations to the designs without prior notice.